

Engineered Timing Belts



Engineered Belts – creating a custom-made product

Ammeraal Beltech has an outstanding reputation for developing individual solutions for each separate belting application. We understand that your processes and equipment are unique to your business, and our engineers have the technical proficiency and the industry experience to develop belts for even the most challenging operating conditions.

Cleats

- Timing Belts customised with welded- on profile/cleats made from the same polyurethane as the body of the belt
- Integrated metal teeth to enable mechanical attachment of cleats
- Both simple upright and custom-made complex-shape cleats available
- Welding
 - infrared welding
 - friction welding
 - contact heated tool welding
- High frequency



Endlessing

- Splicing
- Welded joint
 - only done with open-end PU Linear types
 - finger joint, tapered fingers
 - no glues or adhesives
 - strength after welding at 50% of original maximum belt strength
- Fasteners
 - for specialized tasks
 - plastic lace fastener
 - pin-joint fastener
 - quick installation on site
- Jointing tools
 - finger-punch
 - splice press
 - welding moulds per belt pitch type
 - control unit
 - water-cooling unit
 - jointing on site also possible



V-guides

- Fabricated Vee-guides
 - for PU Linear, PU Torque and PU Moulded belts
 - can be fit to any belt type in any width, length combination
 - can be glued on
 - can also be added onto the back side of the belt
 - special dimensions, colours and degrees of hardness available
 - special notched types available for extra flexibility
- Timing Belts with integrated V-guides
 - PU compound, hardness and colour that match the body of the belt

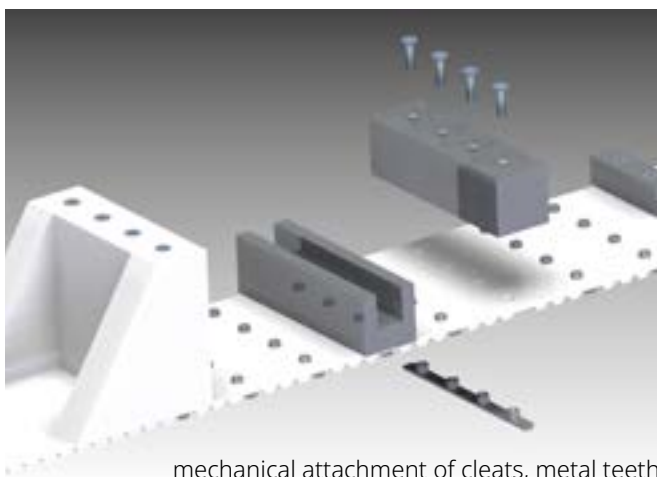
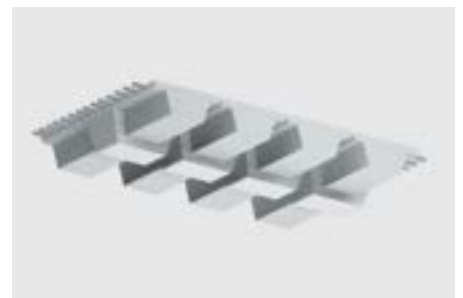

mechanical attachment of cleats, metal teeth

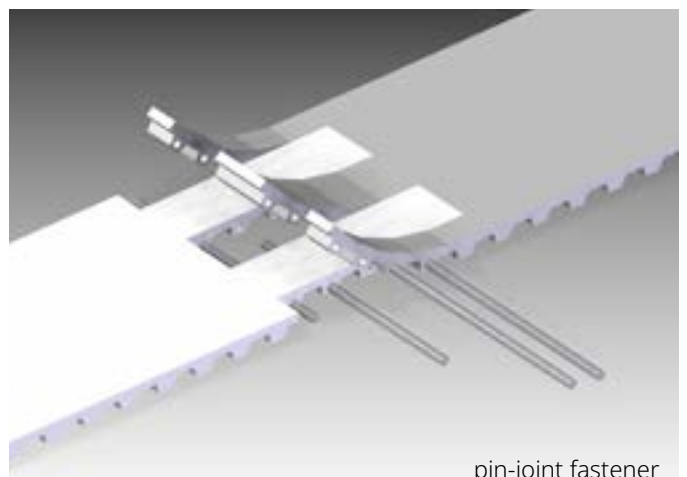

pin-joint fastener



Machining

- Grooves for V-guides and for vacuum belts
- Holes created by water jet cutting, punching or drilling
- Grinding full surface or profiles, such as Poly-V profile
- Cross slots and slits
- Machinery customised to your design
- Embossing of thermoplastic covers
- Milling recessed slots

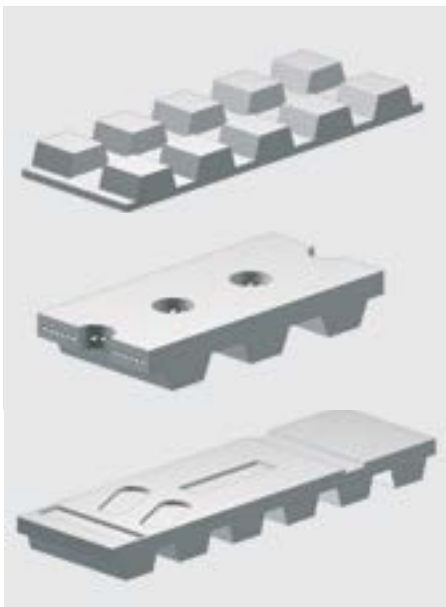

Covers

Cover materials determine a belt's unique set of properties, such as friction, flexibility, wear resistance and oil and fat resistance. Ammeraal Beltech can apply an extra cover to almost any base belt, whether it is a standard belt, a high-performance flat belt or a timing belt. We offer an extensive range of cover materials, including rubbers, PVC, polyurethane, cellular materials and other special materials.

What's more, we can fit a cover to a base belt using any one of four processes:

Bonding

with glue, warm or cold, relatively easy, one off, economic, not seamless

Welding

with hot air, only thermoplastics, seamless if required

Casting

vulcanizing truly endless rubber covers, resulting in a seamless cover

Coating

knife coating for paste covers and for truly endless seamless covers



Covering Materials: Rubber



NRS 035 yellow
Natural rubber, excellent grip with good abrasion resistance



NRS 040 red
Natural rubber, High-grip, good wear and abrasion resistance



NRS 040 white FG
Natural rubber, High-grip, good wear and abrasion resistance, food quality



NRS 040 beige
Synthetic natural rubber, High-grip, excellent for profiling and grooving, high tear and abrasion resistance



NRS 060 red
Natural rubber, high wear and abrasion resistance, good cut and tear resistance



NRS 070 purple
Natural rubber, excellent wear and abrasion resistance, high cut and tear resistance



NTS 065 white FG
Nitrile rubber, oil and fat resistant synthetic rubber, food quality



NTS 060 black
Nitrile rubber, very good wear and abrasion resistance under high temperatures, oil and fat resistance



NTS 070 green
Nitrile rubber, oil and fat resistant, good grip, light fabric texture surface, good wear and abrasion resistance



CXS 065 C37 blue
Nitrile rubber, high wear and abrasion resistant, oil and fat resistance, C37 supergrip profile



SRS 040 C37 tan
Synthetic rubber, high wear and abrasion resistance, sensitive grip, C37 supergrip profile



SRS 040 N19 white
Synthetic rubber, good wear and abrasion resistance, good grip, N19 nipple profile

Rubber

Type	Material	Hardness [°ShA]	Density [kg/m ³]	Colour	Max. contact temperature [°C]	Oil and fat resistance	Static coeff. of friction to steel	Food Grade	Pulley factor	Standard thickness [mm]
NRS 035 yellow	natural rubber	35	990	yellow	+65	low	1.2	no	13	3, 4, 5, 6, 8, 10, 12, 15, 20, 25, 30
NRS 040 red	natural rubber	40	980	red	+70	low	1.0	no	15	1.6, 2.4, 3.2, 5, 6, 8, 10, 12, 15
NRS 040 white FG	natural rubber	40	1000	white	+70	limited	1.0	yes	15	2, 3, 5, 6, 8, 10
NRS 040 beige	synthetic rubber	40	1000	beige	+70	low	1.1	no	15	4, 6, 8, 10, 12, 15
NRS 060 red	natural rubber	60	1100	red	+75	low	0.9	no	17	3, 5, 6, 8, 10, 12, 20, 25
NRS 070 purple	natural rubber blend	70	1130	purple	+75	limited	0.6	no	20	3, 4, 5, 6, 8, 10, 12, 15, 20, 25
NTS 065 white FG	nitrile rubber	65	1300	white	+80	good	0.8	yes	18	5, 10
NTS 060 black	nitrile rubber	60	1300	black	+110	good	0.7	no	18	4, 6, 8, 10, 12
NTS 070 green	nitrile rubber	70	1200	green	+100	good	0.7	no	25	1, 2
CXS 065 C37 blue	nitrile rubber	65	750	blue	+120	excellent	0.9	no	20	4.3
SRS 040 C37 tan	synthetic rubber	40	800	tan	+80	limited	1.0	no	15	4.3
NTS 050 C37 red	nitrile rubber	50	1200	red	+120	excellent	0.7	no	20	4.3
SRS 040 N19 white	synthetic rubber	40	1700	white	+80	limited	na	no	20	2

Covering Materials: PU & PVC



PUS 060 blue/black
Polyurethane, High-grip, flexible, very tough, embossing possible



PUS 080/BS white
Polyurethane, excellent cut and wear-resistant, good oil and chemical resistance



PUS 080 transparent
Polyurethane, High-grip, high abrasion resistance, cut and tear resistance, embossing possible



PVS 030 P6 green/blue
PVC, good chemical resistance, High-grip, P6 supergrip profile



PUS 085 blue AM FG
Polyurethane, good abrasion resistance, excellent oil and fat resistance, AntiMicrobial, food quality



PVS 030 P7 blue
PVC, good chemical resistance, High-grip, P7 minigrip profile



PUS 085 A16 blue AM FG
Polyurethane, good abrasion resistance, excellent oil and fat resistance, AntiMicrobial, A16 profile



PVS 035 blue
PVC, High-grip, limited oil and grease resistance, embossing possible

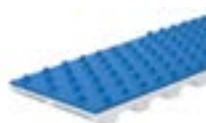

PUS 085 A5 blue FG
Polyurethane, good abrasion resistance, excellent oil and fat resistance, A5 nipple profile



PVS 065 A24 white FG
PVC, good oil and grease resistance, good chemical resistance, haringbone profile



PUS 092 white
Polyurethane, excellent abrasion resistance, good oil and fat resistance



PVS 065 A13 white
PVC, good oil and grease resistance, good chemical resistance, sawtooth profile

PU & PVC

Type	Material	Hardness [°ShA]	Density [kg/m ³]	Colour	Max. contact temperature [°C]	Oil and fat resistance	Static coeff. of friction to steel	Food Grade	Pulley factor	Standard thickness [mm]
PUS 060 blue/black	Polyurethane	60	1150	blue, black	+80	good	0.9	no	25	2.5
PUS 080 transparent	Polyurethane	80	1110	transp.	+80	good	0.8	no	30	1, 2, 3, 4
PUS 085 blue AM FG	TPU Ropanyl	85	1230	blue	+80	excellent	0.6	yes	30	1.5
PUS 085 A16 blue AM FG	TPU Ropanyl	85	860	blue	+80	excellent	na	yes	20	2.5
PUS 085 A5 blue FG	TPU Ropanyl	85	950	blue	+80	excellent	na	yes	15	3.5
PUS 092 white	Polyurethane	92	1300	white	+80	excellent	0.6	no	30	2, 3
PUS 080/BS white	PU Ropan BS	80	1000	white	+80	good	0.4	no	25	2, 3, 4
PVS 030 P6 green/blue	PVC Flexam	30	780	blue, green	+90	limited	0.9	no	15	4
PVS 030 P7 blue	PVC Flexam	30	800	blue	+90	limited	0.9	no	15	4
PVS 035 blue	PVC Flexam	35	1390	blue	+90	limited	1.1	no	20	1, 2, 3
PVS 065 A24 white FG	PVC Nonex	65	660	white	+90	good	na	yes	18	4
PVS 065 FG blue/white	PVC Nonex	65	1330	blue, white	+90	good	0.7	yes	25	2, 3, 4
PVS 065 blue AM FG	PVC Nonex	65	1330	blue	+90	good	0.7	yes	25	1.5
PVC 065 P13 white	PVC Nonex	65	750	white	+90	good	na	yes	18	4

Covering Materials: Cellular



NRS 160 grey/orange
Natural rubber, open cellular construction, high resilience, high elasticity and porosity, compressible



PUS 220 blue
Polyurethane, low density partially closed cellular construction, good oil and fat resistance



NRS 200 black
Natural rubber, open cellular construction, High-grip, high resilience, high elasticity and porosity, compressible



PUS 300 green
Polyurethane, medium density partially closed cellular construction, good abrasion resistance



NRS 250 orange
Natural rubber, open cellular construction, non-marking, high resilience, high elasticity and porosity



PUS 400 brown
Polyurethane, high density partially closed cellular construction, good abrasion resistance



NRS 270 green
Natural rubber, open cellular construction, High-grip, non-marking, high resilience



PUS 400 beige
Polyurethane, high density closed cellular construction, excellent wear resistance

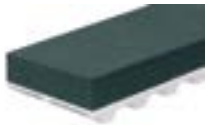

NES 290 black
Neoprene rubber, closed cellular construction, very High-grip, good oil and chemical resistance



PUS 600 yellow
Polyurethane, very high density fully closed cellular construction, good wear and abrasion resistance



FBS 160 blue
Closed cellular neoprene rubber covered by premium stretch fabric, low friction surface

Cellular

Type	Material	Hardness [°ShA]	Density [kg/m³]	Colour	Max. contact temperature [°C]	Oil and fat resistance	Static coeff. of friction to steel	Food Grade	Pulley factor	Standard thickness [mm]
NRS 160 grey/orange	natural rubber, open cellular	-	160	orange, grey	+65	low	1.0	no	6	5, 10, 15, 20, 25, 30
NRS 200 black	natural rubber, open cellular	-	200	black	+65	low	1.0	no	6	3, 5, 8, 10, 15,
NRS 250 orange	natural rubber, open cellular	-	250	orange	+65	low	1.0	no	8	5, 10, 15, 20, 25, 30
NRS 270 green	natural rubber, open cellular	-	270	green	+65	low	1.0	no	8	5, 10, 15
NES 290 black	neoprene rubber, closed cellular	-	290	black	+85	good	1.3	no	10	5.5, 7, 10.5, 13, 30
FBS 160 blue	fabric covered cellular neoprene	-	160	blue	+70	good	0.3	no	15	3, 6
PUS 220 blue	cellular polyurethane	-	220	blue	+70	good	0.5	no	12	5, 7, 11, 12, 14, 25
PUS 300 green	cellular polyurethane	-	300	green	+70	good	0.5	no	14	4, 5, 7, 10, 11, 12, 14, 25
PUS 400 brown	cellular polyurethane	-	400	brown	+70	good	0.5	no	15	3, 5, 11, 12, 14, 25
PUS 400 beige	cellular polyurethane	-	400	beige	+80	good	0.3	no	16	1, 2, 3, 4, 5, 6
PUS 600 yellow	micro cellular polyurethane	50	600	yellow	+70	excellent	0.4	no	20	2, 3, 4, 5, 6, 8, 10

Covering Materials: Special



PRs 060 blue/red
Technopolymer, High-grip, good abrasion resistance, light embossing possible, silicon-free, good flexibility at low temperatures



AMS 090 A16 ivory
Polyester, good abrasion resistance, excellent oil and fat resistance, A16 nipple profile



CLS 925 grey
Chrome leather, high abrasion resistance, medium grip, good for oily and greasy circumstances



SIS 060 blue
Silicone rubber, good wear and abrasion resistance, self-releasing surface



NPS 055 brown/white
Needle punched polyester fabric, low grip, high abrasion and wear resistance



SIS 040 light blue FG/white
Silam silicone rubber, excellent tear strength, High-grip, self-releasing surface, food quality



PES 999 grey
Needle punched polyester fabric impregnated, low grip, high abrasion resistance



ELS 060 green
Technopolymer, High-grip, good oil and fat resistance, excellent abrasion and tear resistance



PAS 778 green
Low friction and low noise nylon fabric, excellent wear resistance, good oil and chemical resistance



KFS 999 yellow^{*)}
Aramid felt, heat resistant, good abrasion resistance, good oil and fat resistance



PLS 035 red
Pletex poly blend, High-grip, limited oil and grease resistance, embossing possible

Special

Type	Material	Hardness [°ShA]	Density [kg/m ³]	Colour	Max. contact temperature [°C]	Oil and fat resistance	Static coeff. of friction to steel	Food Grade	Pulley factor	Standard thickness [mm]
PRs 060 blue/red	thermoplastic technopolymer	60	1030	blue, red	+80	good	0.9	no	25	2.3
CLS 925 grey	chrome leather	-	930	grey	+80	excellent	0.8	no	30	3
NPS 055 brown/white	needle punched polyester fabric	-	560	brown, white	+80	good	0.3	no	25	2.5 (white: 2)
PES 999 grey	polyester fabric	-	1400	grey	+80	good	0.3	no	25	2.0
PAS 778 green	nylon fabric	-	220	green	+80	good	0.3	no	-	0.5
PLS 035 red	Pletex poly blend	35	1385	red	+90	limited	0.9	no	20	2, 3, 4
AMS 090 A16 ivory	Amtel polyester	90	450	ivory	+100	excellent	na	yes	30	2.5
SIS 060 blue	silicone rubber	60	1600	blue	+220	good	0.6	no	17	3.2, 5.0, 7.0
SIS 040 l bl. FG, white	silicone rubber Silam	40	1120	blue, white	+250	excellent	1.3	yes	15	1-10
ELS 060 green	Elastonyl technopolymer	60	1060	green	+80	good	0.9	no	25	2.4
KFS 999 yellow ^{*)}	Aramid felt	-	320	yellow	+480 ¹⁾	good	0.3	no	na	10

^{*)} also available PBO felt +600°C, Nomex felt + 280°C, Polyester felt +180°C

¹⁾ surface contact temperature

A solution for every application

Engineered Belts can be found performing a wide variety of tasks in many different industries. Each belt is specialised to meet specific needs.

Feeder belts

Many folder gluer machines in the Corrugated Industry have feeder belts from Ammeraal Beltech to feed the corrugated box dies. Our Ultrafeed 500 cover, with its exceptional friction and wear resistance, gives our feeder belts excellent performance and a long service life. In addition, our food-approved belt covers meet FDA/EC regulations.



Product benefits:

- Consistent feeding of the corrugated box dies to improve productivity and yield
- Non-marking covers to help reduce waste and scrap
- Reduced maintenance costs due to long service life
- FDA/EC approved feeder belt covers that meet government and customer demands for Food Safety

Sausage belts

In the Meat Industry, Food Safety is key. With our blue food-approved AntiMicrobial sausage belt covers, you are ready to meet and exceed the most challenging Food Safety demands.

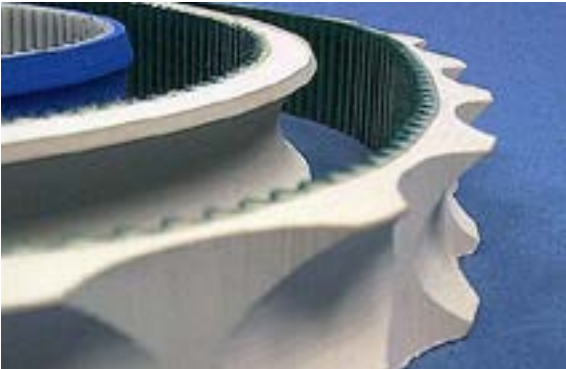

Product benefits:

- Constant product feed due to the excellent soft grip of our Silam covers, even in cold, greasy circumstances
- Highly flexible cover ensuring maximum productivity and belt life, even at reduced ambient temperatures
- Reduced damage to the sausages due to gentle linking process and continuous transport
- AntiMicrobial properties to support your ISO 22000 requirements (previously HACCP), and sealed edges to protect belt reinforcement and eradicate possible product contamination

Haul-off and cable-pulling belts

Haul-off and cable-pulling belts, designed to operate in pairs on caterpillars, are precision-made to exact specifications. The hardness, thickness and friction properties of the covers combine to deliver excellent pulling/clamping force ratio, and their special wear-resistance and low-aging qualities ensure a long service life.



Product benefits:

- Equal thickness of belt pair over entire length for reliable uniformity of speed
- A wide range of covers offering different hardness and friction coefficients
- Longitudinal profiles for better fit-grip
- Heat and chemical-resistant covers for particularly demanding applications
- Different base belts available, including Poly-V, flat belts and timing belts

Top-compression and seam-compression belts for the Corrugated Industry

After folded boxes have been glued, top-compression and seam-compression belts hold them carefully in place during transport and drying. The weight of the belt holds the boxes down and the soft thick belt cover adapts to the shape of any folded box, large or small. What's more, our belts have been specially constructed from non-marking flexible materials to carefully compress boxes in order to preserve product quality.



Product benefits:

- Belt adapts to the size and shape of your product for better compression
- Soft and compressible top cover to reduce product damage
- FDA compliant Food Grade top covers available
- Available with a truly endless top cover for improved belt performance

Belts for the Sanitary Paper Industry

Belts for the Sanitary Paper Industry are designed to strict job specifications. Products such as diapers and sanitary pads are assembled with high precision on moving belts at speeds up to 400 meters per minute. These positive drive belts are key to the synchronous assembly lines used for these products. The high-friction covers, together with the vacuum that is applied, hold the product in place while it is assembled, cut, folded and packed.



Product benefits:

- No product slip, thanks to vacuum feature and high friction covers, for maximum efficiency
- Excellent running properties at high speeds for greater productivity
- Precise product positioning for smoothest possible workflow
- Available with non stick silicone cover

Pull-down Belts

Vertical Form-Fill & Seal (VFFS) bagging machines are widely used, particularly in the Food and Chemical Industries. Typical products that are packed using this equipment are sweets, cheese, coffee, deep-freeze products, chemicals, sand and soil, and small plastic products.

The function of the pull-down belts is to consistently move a plastic film (wrapped around a steel tube) downwards in a controlled start-stop movement. This is a demanding application and requires high-performance belts with friction covers that are both wear-resistant and tear-resistant. Our pull-down belts are ideal for this work, and they're all non-marking and machined specifically to fit the task they perform.



Product benefits:

- Constant and secure foil pull
- Non-marking belt covers to safeguard product quality
- Wear-resistant belt surface for a longer service life